



29979 Harvester Rd, Malibu, CA. 90265
Telephone: (818) 371-7128, e-mail: kodian@verizon.net

DOCUMENT NO. OE-08-05-301

**TEST REPORT:
STEELDECK PLATFORM SYSTEMS
STRUCTURAL CAPACITY**

Revision F Dated Oct. 1, 2024

Prepared for: **Steeldeck, Inc.**
13147 S Western Avenue
Gardena, CA 90249-1921

Approved By:

Name (print):

Title:

Kirk Odian

President, M.S., P.E.

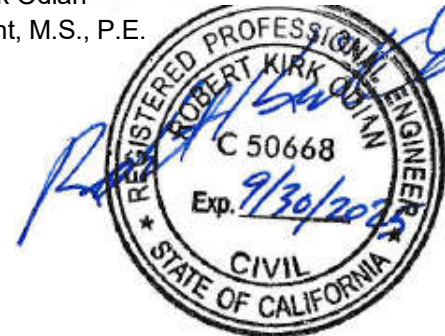

PROPRIETARY DOCUMENT

The Information herein is privileged and confidential and shall not be disseminated, duplicated, reused or disclosed in any way without the prior written permission of STEELDECK, Inc. or Odian Engineering, Inc.



Log of Revisions

Revision Letter	Page Number	Section	Description of Change
IR	all	all	Initial release
A	23-31	5.0 & 6.0	Added Section
B	All	All	Included current CBC 2013 Compliance, changed “stage” to “platform”.
C	2	1.1	Corrected typo error: changed 3” to 3’ in 2 nd Para.
D	23-31	5.0 & 6.0	Corrected Report Number typo in header.
E	Cover page		Updated for new Steeldeck address.
F	Cover page, i, v, 1, 5 & 23	1.0, 1.2 & 5.0	Updated to cite latest CBC 2022 revision.

Table of Contents



Log of Revisions i
List of Figures..... iii
List of Tables..... iv
References v
1.0 INTRODUCTION 1
 1.1 Background 2
 1.2 Test Objective..... 5
 1.3 Previous Work 6
 1.4 Limitations..... 7
2.0 EQUIPMENT, PROCEDURES AND TEST PARAMETERS 8
3.0 PLATFORM TEST 13
4.0 TEST RESULTS 22
5.0 SUMMARY OF FINDINGS 23
 5.1 Other Steeldeck Offered Shape and Sized Decks Bounded by these Test Results 24
6.0 Appendix: dwg HEAMS106103 Rev. 0, dated 4/17/07..... 29



List of Figures

Figure 1-1 Standard STEELDECK® Rectangular Platforms.....1

Figure 1-2 Typical STEELDECK® Common Leg Joint3

Figure 1-3 Typical STEELDECK® Deck-to-deck Connecting Bolt Joint4

Figure 1-4 Tributary Loading of Test Configuration Critical Central Leg.....5

Figure 1-5 Manufacturer’s “Company Test”6

Figure 2-1 Test Platforms.....8

Figure 2-2 Test Platform, View from below of Critical Central Leg.....9

Figure 2-3 Test Platform, Long View from below9

Figure 2-4 Symmetrically loaded pallet10

Figure 2-5 Cement Bag, 94 lbs min11

Figure 2-6 First Platform loaded to 135.5 lbs/ft²11

Figure 3-1 Load Step 1, 1st Platform loaded to 135.5 lbs/ft²13

Figure 3-2 Load Step 2, 1st Platform loaded to 271.0 lbs/ft²14

Figure 3-3 Load Step 2, 1st Platform loaded to 271.0 lbs/ft², Sag of long side beams15

Figure 3-4 Load Step 2, 1st Platform loaded to 271.0 lbs/ft², Inboard long beams.....16

Figure 3-5 Load Step 2, 1st Platform loaded to 271.0 lbs/ft², Inboard long beams.....17

Figure 3-6 Load Step 3, 1st Platform unloaded, Complete Elastic Recovery of side beams.....18

Figure 3-7 Load Step 4, 2nd Platform loaded to 147.25 lbs/ft².....19

Figure 3-8 Load Step 4, 2nd Platform loaded to 147.25 lbs/ft², 3/16” Sag of 8’ long beams.....20

Figure 3-9 Load Step 15, 1st Platform, No distress of critical deck-to-deck bearing surfaces.....21

Figure 3-10 Load Step 15, 2nd Platform, No distress of critical deck-to-deck bearing surfaces.....21



Report OE-08-05-301

Rev. F

List of Tables

Table 2-1	Loading Sequence & Procedure.....	12
-----------	-----------------------------------	----



Report OE-08-05-301

Rev. F

References

1. 2007 California Code of Regulations, Title 24, Part 2, *California Building Code*
2. 2001 California Code of Regulations, Title 24, Part 2, *California Building Code*
3. 1994 Uniform Building Code, Volume 2, Structural Engineering Design Provision.
4. Steeldeck, Set-up and Safety Manual, Rev. 5/2002.
5. Steeldeck, Platform Systems Catalog, May 2002.
6. British Standards Institution Specification BS 1139: Part 2: 1982, Metal Scaffolding.
7. British Standards Institution Specification BS EN 74-1:2005, Couplers, spigot pins and baseplates for use in falsework and scaffolds, Part 1: Couplers for tubes – Requirements and test procedures.
8. 4'x 8' Steeldeck® Platform Evaluation, Rev. 1 dated April 2007, Hopper Engineering Associates, PRO 196
9. 2013 California Code of Regulations, Title 24, Part 2, *California Building Code*
- 10. 2022 California Code of Regulations, Title 24, Part 2, *California Building Code***



1.0 INTRODUCTION

This test report presents independent testing and findings conducted by Oedian Engineering of the Steeldeck® 4'x 8' platform system. The prior Revision "A" of this report presented the testing conducted to further substantiate the structural integrity of the subject platform system, beyond that of the analytical substantiation of Reference 8, by way of live load testing consistent with the then 2007 California Code of Regulations, Title 24, Part 2, Chapters 16 & 17. **This subsequent Revision "F" of the test report shows continued compliance with the current 2022 California Code of Regulations, Title 24, Part 2, Chapters 16 & 17.** A system of four (4) 4'x 8' decks, assembled in accordance with the manufacturer's Set-up and Safety Manual (Ref. 4) was tested herein. This configuration was chosen as it contains the largest free span of the typical deck components offered, and it subjects the deck and leg support joints with the most critical loading. As such, these test results bound a number of smaller, less critical deck components offered as will be discussed in the Summary.

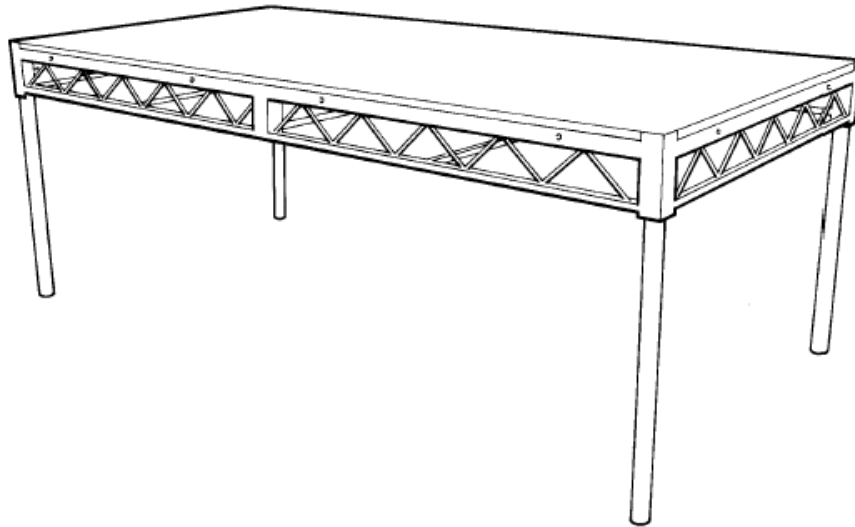

Figure 1-1 Standard STEELDECK® Rectangular Platforms



1.1 Background

Steeldeck manufactures platform systems for sale and rent. These systems are typically employed as assembled platforms in various private and sometimes public venues. Often, the platforms are assembled as a connected system to erect a large platform of variable shape. This is accomplished by virtue of the modular design and the ability to connect the individual platforms of different sizes and shapes together.

As previously stated, a system of four (4) 4'x8' decks assembled together as an 8'x 16' rectangular platform 3' high was selected as the test configuration. This configuration was selected since it represents the critical spans, maximum joint loading and most typical platform height.

When erecting an assembled platform, the first deck is set on four (up to six for some shapes) corner legs which are captured in the corner sockets. On legs which will be common to the adjoining decks, couplers (see reference 5, Steeldeck catalog) are then clamped just below the corner socket, as an assembly aid. The couplers provide a temporary support for the neighboring platforms to be placed on. The neighboring decks receive legs in their outboard corner sockets which do not rest on the first deck's couplers. At the common edges of all decks, frame connecting bolts are installed which secure the two decks together. Thus the central leg common to the first deck in the selected test platform configuration will bear $\frac{1}{4}$ of the live load from the four assembled decks. The following Figures show the typical platform erection process, erection aid couplers, fixed deck-to-deck connection bolts and the critical test assembly and load sharing.

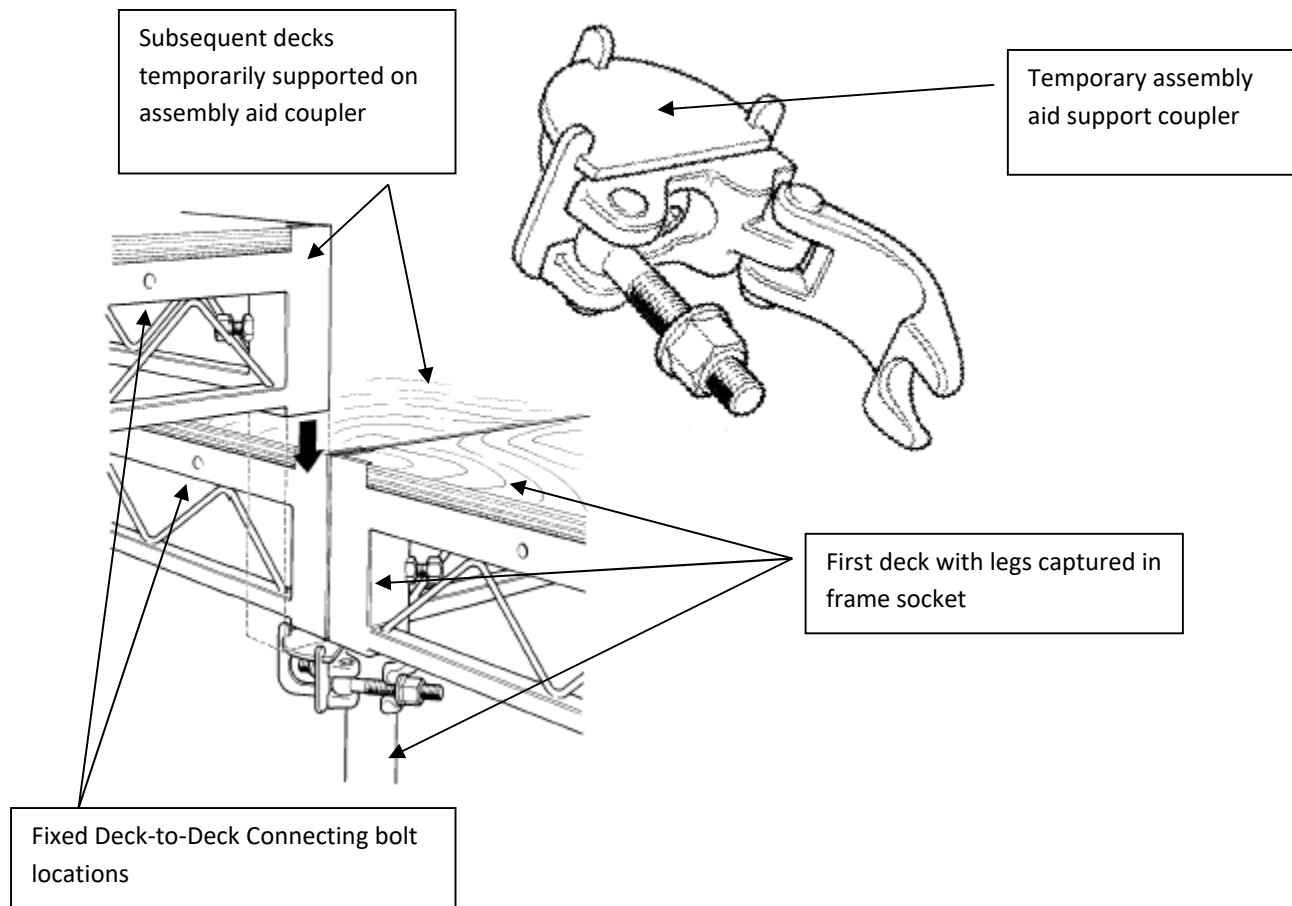

Figure 1-2 Typical STEELDECK® Common Leg Joint



Figure 1-3 Typical STEELDECK® Deck-to-deck Connecting Bolt Joint

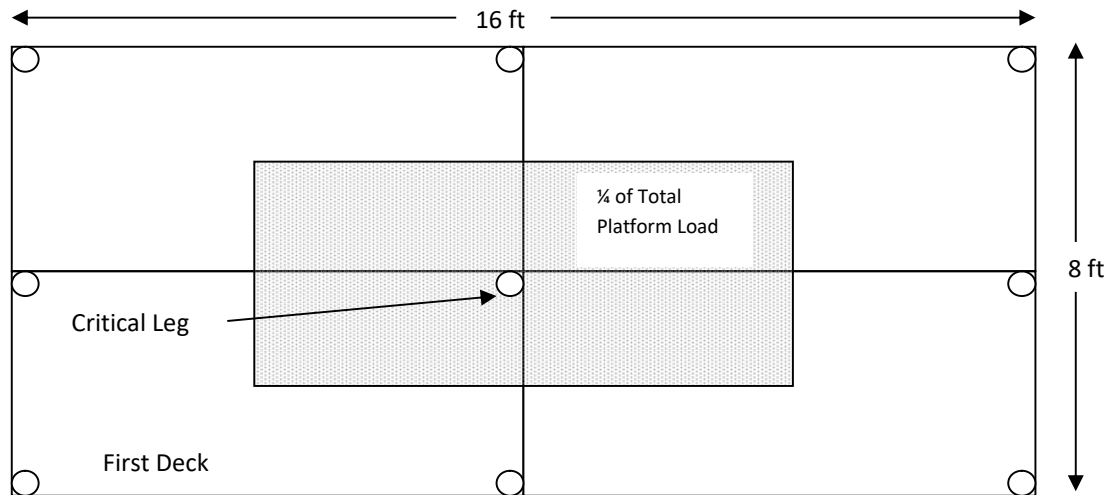

Figure 1-4 Tributary Loading of Test Configuration Critical Central Leg

1.2 Test Objective

The 2022 California Code of Regulations, Title 24, Part 2, Chapters 16, Table 1607.1, Minimum Uniformly Distributed Live Loads and Minimum Concentrated Live Loads, establishes the required loading for platforms (assembly) as 100 lbs/ft². Section 1709 of the same code sets forth In-Situ Load Test methodology. Consistent with the intent of Section 1709, the objective of this testing was to subject the platform assembly equal to two times the unfactored Design Load (2x100 = 200 lbs/ft²). It is noted that the testing previously carried out and reported in the IR and A Revisions employed a conservative 125 lbs/ft² Design Load. The test procedure employed has been developed by this author, a registered Professional Engineer in the State of California. The test procedure simulates loads and conditions of application that the completed structure or portion thereof will be subjected to in normal use. The structure shall be considered to have successfully met the test requirements where the following criteria are satisfied:

1. Under the conservatively assumed Design Load (125 lbs/ft²), the deflection shall not exceed the limitations specified in California Code of Regulations, Title 24, Part 2, Section 1604.3 (longest span/360 inches).
2. Upon removal of the test load, the structure shall have undergone no permanent deformation.
3. During and immediately after the test, the structure shall not show evidence of failure.

1.3 Previous Work

Reference 8 contains an analytical structural substantiation of the same 4'x 8' Standard deck. That analysis was performed by Hopper Engineering under the supervision and approval of a Registered Professional Engineer. The analysis contained both classical closed form hand calculations as well as a detailed Finite Element Analysis of the deck. The same Design Load of 125 lbs/ft² was substantiated in that report.

The subject platform systems, as designed, have been in use for over 20 years primarily in the entertainment industry. They have been subjected to on the job in-situ loading of similar magnitude reportedly without any catastrophic incident. Typically the on the job loading demands placed on the platforms is far less than the aforementioned design requirements.

The manufacturer conducted a similar test as that proposed herein; "Company Test". He erected a 2 ft high, four 4'x 8' deck platform and loaded one deck quadrant with 12,700 lbs of tare weight in racks. This represented nearly 400 lbs/ft², but the load was not necessarily uniformly loaded, and only one deck quadrant was loaded.



Figure 1-5 Manufacturer's "Company Test"



1.4 Limitations

The results of the testing proposed herein is limited to the following:

1. Deck modules made of the same grade and truss beam configuration as that which was tested (per dwg HEAMS106103 Rev. 0, dated 4/17/07).
2. Deck modules which are smaller or configured with denser support structure resulting in overall lower loading per maximum span, and lower loading per critical leg joint and deck-to-deck connecting bolted joints.
3. Platforms erected to a maximum height of 3 ft.
4. Vertical Live Load conditions.

2.0 EQUIPMENT, PROCEDURES AND TEST PARAMETERS

Two 8'x 16' rectangular platforms were erected on a flat concrete floor inside a warehouse. Both platforms consisted of four Standard 4'x 8' decks, conforming to dwg HEAMS106103 Rev. 0, which were set on 3' legs (1-1/2 Schedule 40 steel pipe) and adjoined together as per the standard procedures outlined in the preceding and in Reference 4. All equipment and hardware were randomly selected from rental stock to ensure a typical "as used" condition. The two platforms were erected to optimize the loading sequence and to ensure that typical erection practices were imposed.

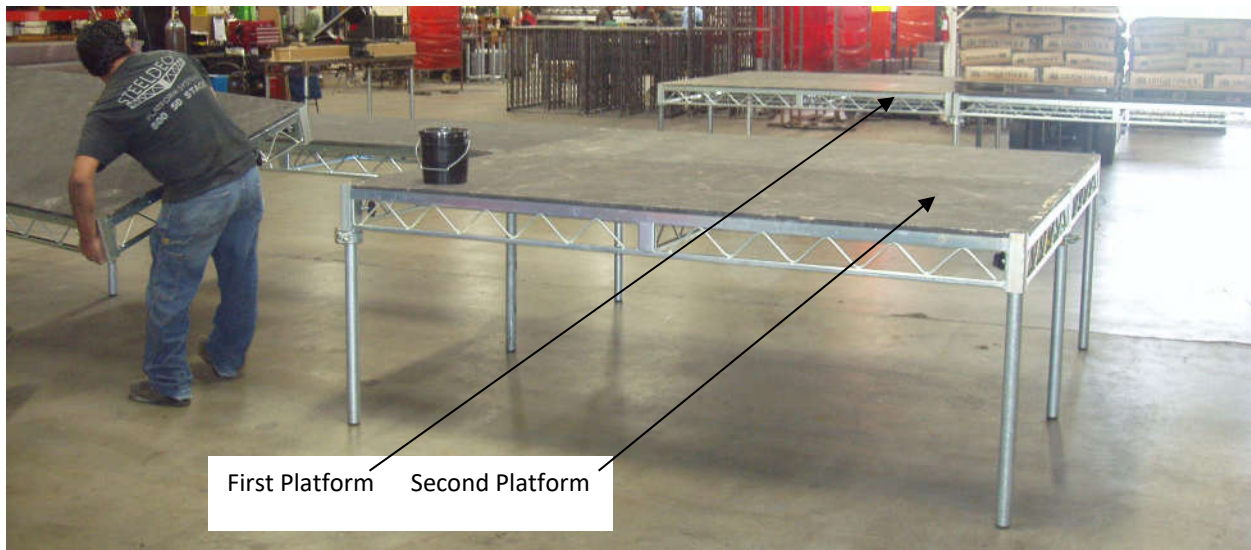

Figure 2-1 Test Platforms



Figure 2-2 Test Platform, View from below of Critical Central Leg



Figure 2-3 Test Platform, Long View from below

Live load consisted of palletized bags of cement placed with fork lifts. Each bag weighed equal to or in excess of 94 lbs. Five randomly selected bags were weighed with the following tare weights: 95, 94, 96, 95.5 & 97 lbs respectfully. The pallets were 4'x 4', reinforced and specially constructed to have continuous bottoms for an even applied distributed load. Each pallet weighed approximately 100 lbs. Three randomly selected pallets were weighed with the following tare weights: 106.5, 112 & 100 lbs respectively. One symmetrically loaded pallet consisted of four layers of 5 bags per layer. On top of the fourth layer, two additional bags were placed for a total of 22 bags per pallet; combined palletized weight = $22 \times 94 \text{ lbs/bag} + 100 \text{ lbs} = 2,168 \text{ lbs.}$, or $2168 \text{ lbs}/16 \text{ ft}^2 = 135.5 \text{ lbs/ft}^2$ (8.4% greater than the 125 lbs/ft^2 Design Load Requirement for conservatism).



Figure 2-4 Symmetrically loaded pallet



Figure 2-5 Cement Bag, 94 lbs min



Figure 2-6 First Platform loaded to 135.5 lbs/ft²



The two platforms were loaded in sequence so that after the first platform had sustained the maximum applied loading dwell, it was unloaded directly to the second platform whereby the second platform would be loaded up to the maximum applied loading. A total of ten load steps were accomplished between the two platforms; each step dwelling for 10 minutes minimum at the selected applied load value. The following table summarizes the load steps and applied distributed loading. It is noted that the odd numbered steps varied in distributed load slightly as the individual extra 2 bags per symmetric pallet were being positioned manually at first, and then ultimately were consolidated as four individual extra bags and left on one pallet layer.

Table 2-1 Loading Sequence & Procedure

Load Step	Platform #	Distributed Load (lbs/ft²)	Dwell Time (min:sec)
1	1	135.5	13:36
2	1	271.0	10:45
3	Unload the entire platform and check for and document any signs of distress.		
4	2	147.25	17:14
5	2	271.0	11:15
6	Unload the entire platform and check for and document any signs of distress.		
7	1	147.25	10:30
8	1	271.0	11:25
9	Unload the entire platform and check for and document any signs of distress.		
10	2	123.75	11:30
11	2	271.0	10:00
12	Unload the entire platform and check for and document any signs of distress.		
13	1	147.25	11:33
14	1	271.0	10:30
15	Unload the entire platform and check for and document any signs of distress.		

3.0 PLATFORM TEST

On April 16, 2008, this author conducted the platform tests as described in the preceding chapter and as shown in the following photographs. All phases of the platform erection, loading and unloading were witnessed by this author. Intermediate inspections and teardown inspections of the test articles were carried out by this author.



Figure 3-1 Load Step 1, 1st Platform loaded to 135.5 lbs/ft²



Figure 3-2 Load Step 2, 1st Platform loaded to 271.0 lbs/ft²



Figure 3-3 **Load Step 2, 1st Platform loaded to 271.0 lbs/ft², Sag of long side beams**



Figure 3-4 Load Step 2, 1st Platform loaded to 271.0 lbs/ft², Inboard long beams



Figure 3-5 Load Step 2, 1st Platform loaded to 271.0 lbs/ft², Inboard long beams



Figure 3-6 Load Step 3, 1st Platform unloaded, Complete Elastic Recovery of side beams



Figure 3-7 Load Step 4, 2nd Platform loaded to 147.25 lbs/ft²



Figure 3-8 Load Step 4, 2nd Platform loaded to 147.25 lbs/ft², 3/16" Sag of 8' long beams

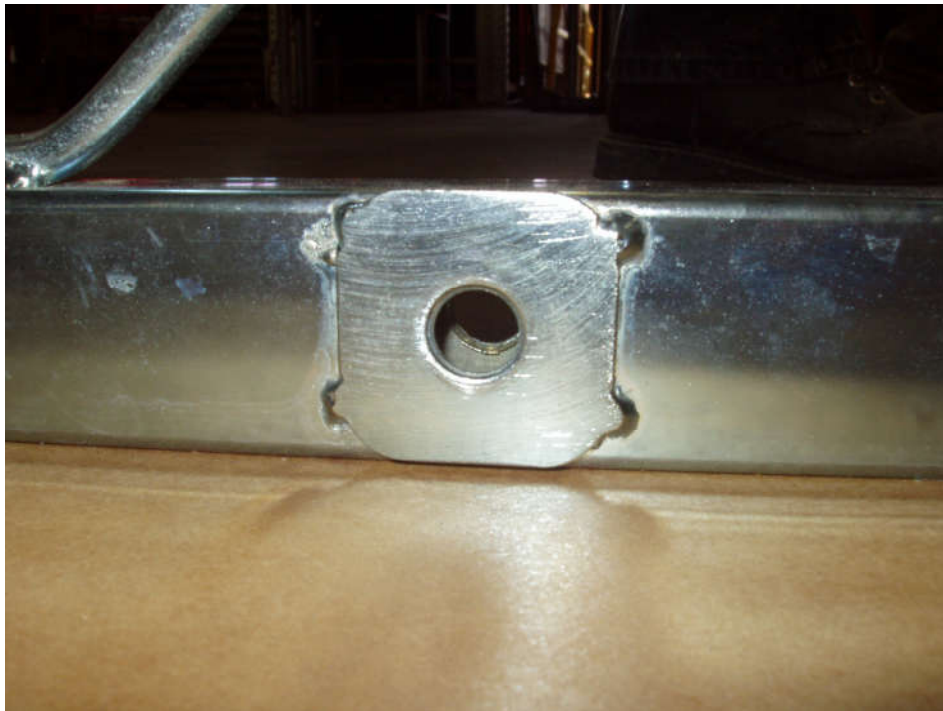

Figure 3-9 Load Step 15, 1st Platform, No distress of critical deck-to-deck bearing surfaces



Figure 3-10 Load Step 15, 2nd Platform, No distress of critical deck-to-deck bearing surfaces



4.0 TEST RESULTS

The structure successfully met the test requirements as follows:

1. Under the conservative Design Load (125 lbs/ft²), the deflection shall not exceed the limitations specified in California Code of Regulations, Title 24, Part 2, Section 1604.3 (longest span/360 inches).

Result: 0.1875 inches of maximum Sag deflection measured at mid span of the long 8 ft beam under a conservative 147.25 lbs/ft² Design Load. $0.1875'' < (8\text{ft} \cdot 12\text{in}/\text{ft})/360 = 0.2667\text{inches}$ allowed.

2. Upon removal of the test load, the structure shall have undergone no permanent deformation.

Result: All decks recovered elastically with no permanent set upon unloading the maximum 271 lbs/ft² loading (= 217% Design Load).

3. During and immediately after the test, the structure shall not show evidence of failure.

Result: At no time during the test or upon teardown inspection were any failures evident.



5.0 SUMMARY OF FINDINGS

The subject Steeldeck® Standard platforms fabricated in accordance with dwg HEAMS106103 Rev. 0, dated 4/17/07, were found to meet and exceed the minimum performance standards of applicable 2022 California Code of Regulations, Title 24, Part 2.

When comparing the design of the critical 4'x 8' Standard deck, to that of the design and configuration of a number of other Steeldeck® offered shapes and sizes fabricated with the same grade and construction as per dwg HEAMS106103 Rev. 0, dated 4/17/07, it is found by inspection that these test results are bounding. This is due to the fact that the other offered shapes and sizes have smaller unsupported spans and greater numbers of legs and deck-to-deck fixed connections per tributary load than the critical 4'x 8' Standard platform on four legs. Thus these other shapes and sizes are less critically loaded while maintaining equal or superior capacity. The list of these other Steeldeck® offered shapes and sizes which are considered bounded by this testing is provided in the following Section 5.1

A Design Load rating of 125 lbs/ft² is acceptable for all the Steeldeck® platform products listed herein.



5.1 Other Steeldeck Offered Shape and Sized Decks Bounded by these Test Results

The following lists the other Steeldeck[®] offered shapes and sizes, which when fabricated with the same grade and construction as per dwg HEAMS106103 Rev. 0, dated 4/17/07, are found to be bounded by the tests herein.

Rectangular

4' x 8'

3' x 8'

2' x 8'

4' x 6'

3' x 6'

2' x 6'

4' x 4' (square)

3' x 4'

2' x 4'

3' x 3'

2' x 3'

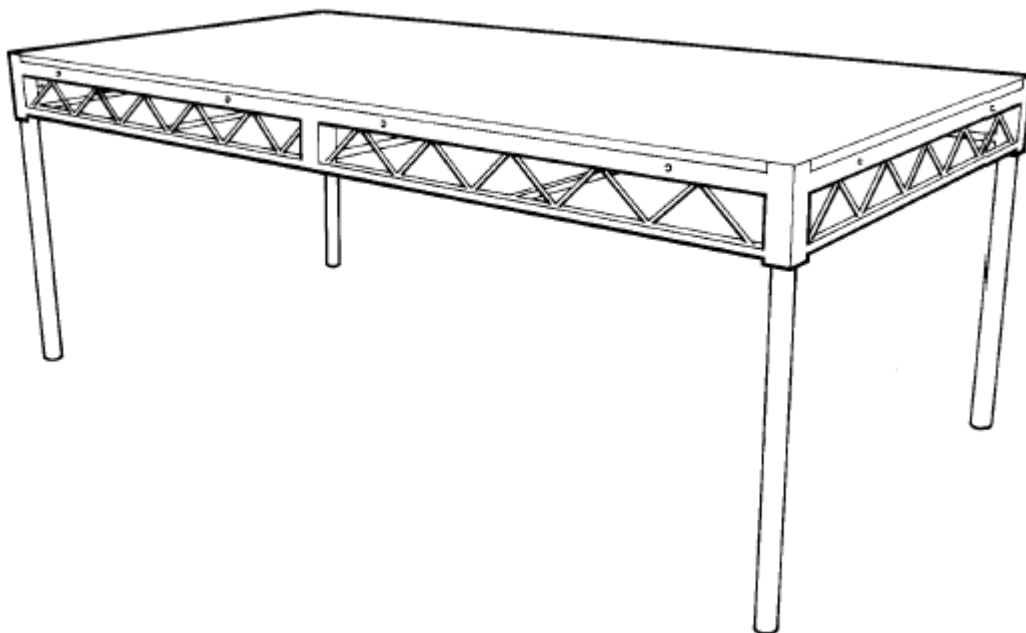



Report OE-08-05-301

Rev. F
Section 5.0

Triangles

4' x 4'

3' x 3'

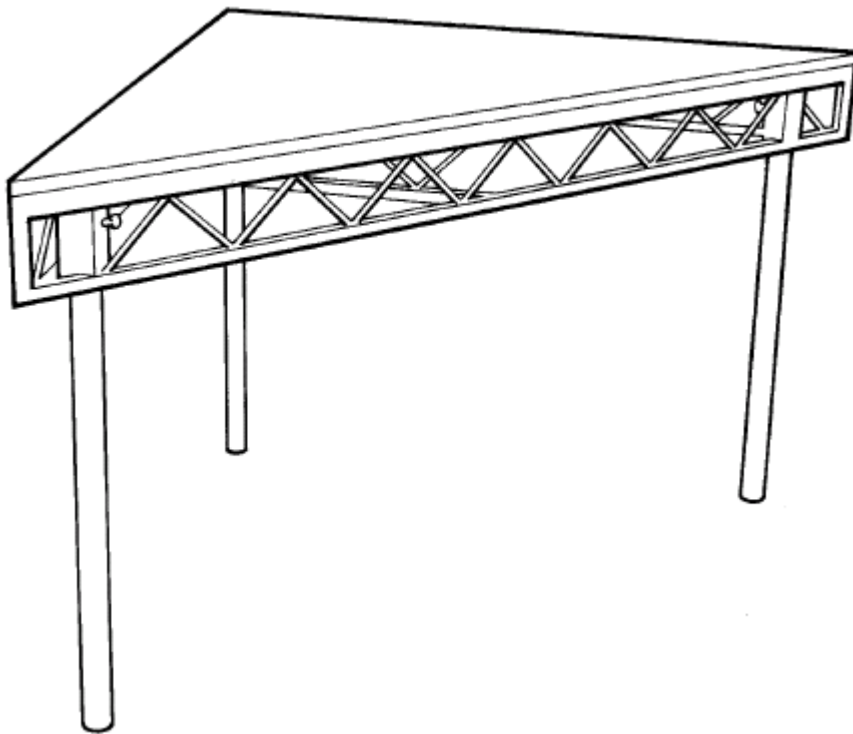



Report OE-08-05-301

Rev. F
Section 5.0

Circles

4' diameter (whole circle)

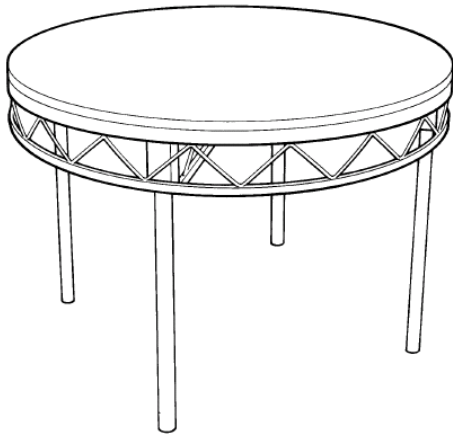

3' Quadrant Deck

6' diameter (3' x 3' quadrants)

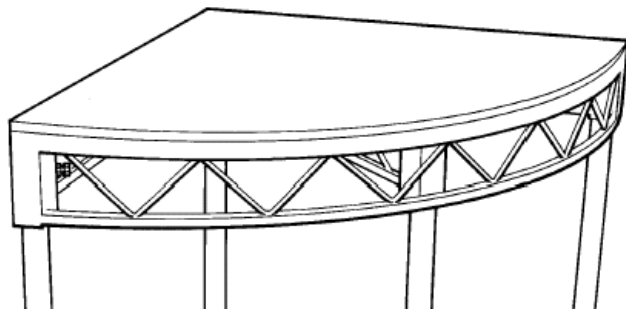

8' diameter (4' x 4' quadrants)

4' Quadrant Deck

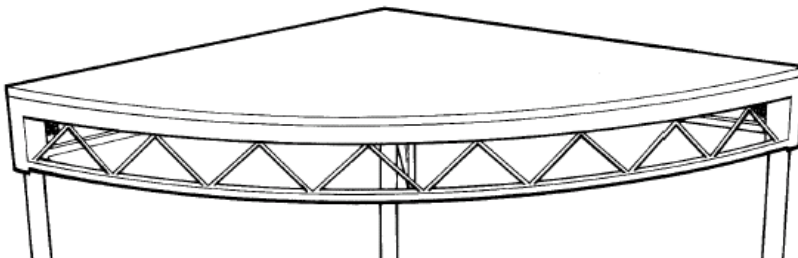



Report OE-08-05-301

Rev. F
Section 5.0

10' diameter (5' x 5' quadrants)
5' Quadrant Deck

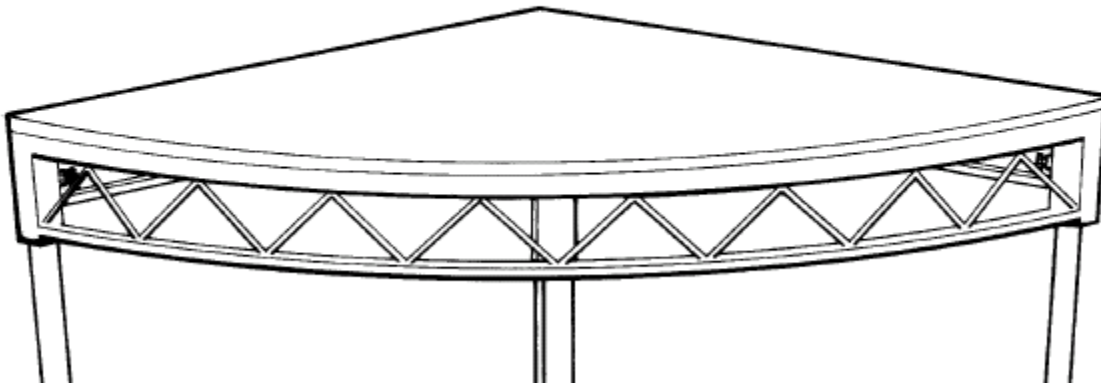

12' diameter (6' x 6' quadrants)

6' Quadrant Deck

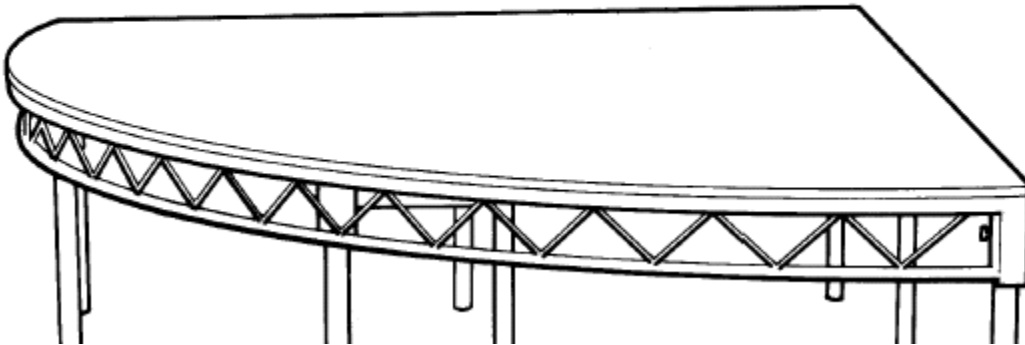



Report OE-08-05-301

Rev. F
Section 5.0

16' diameter (4' x 4' x 5.5' shapes, Left and Right) shown below, top left,
20' diameter (4' x 6' x 7' shapes, Left and Right) shown below top right,
24' diameter (4' x 8' x 8.5' shapes, Left and Right) shown below bottom.

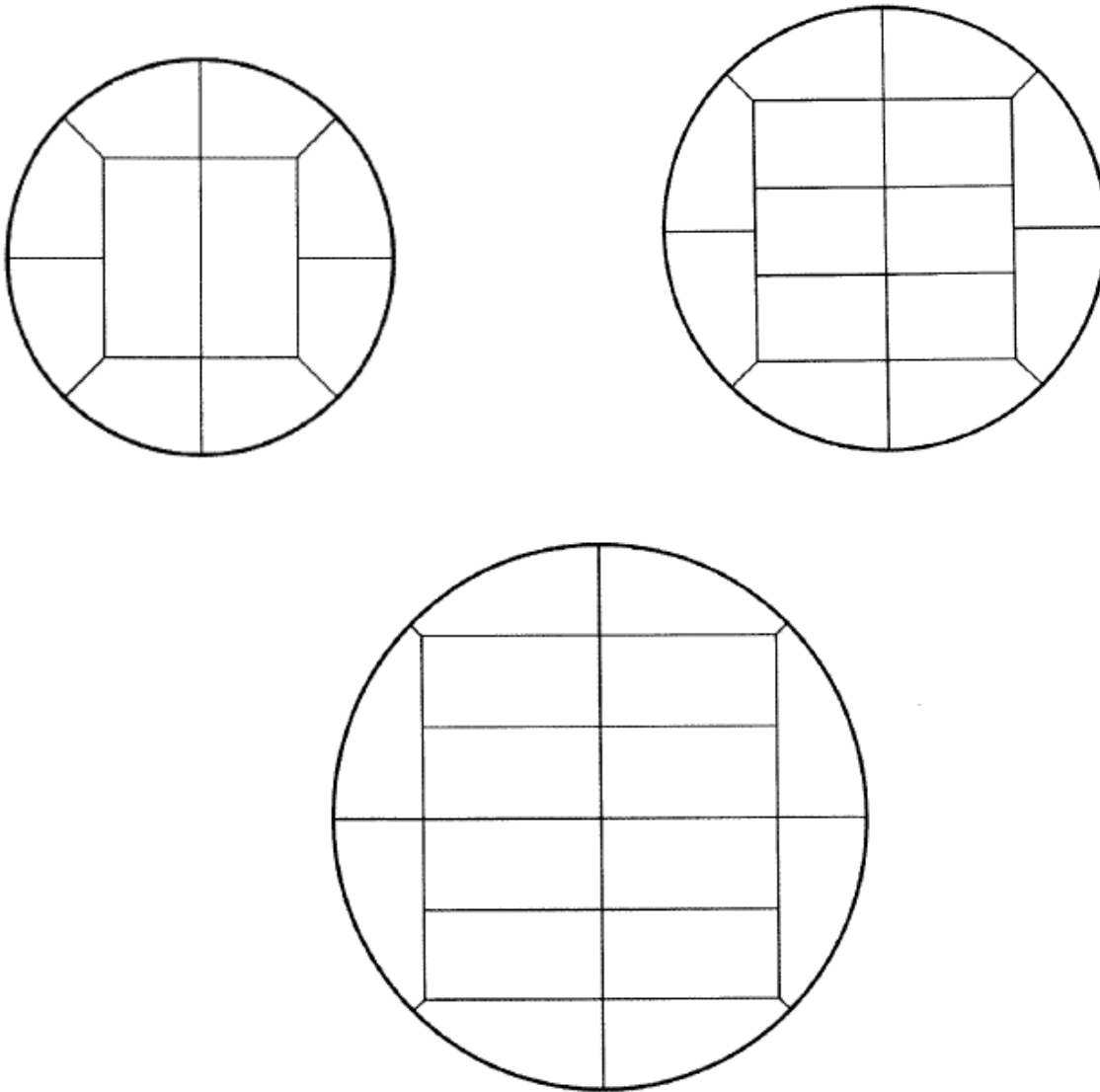

DESCRIPTION:

24' Diameter Deck. Same construction as standard Steeldeck[®] platform using steel truss frame with high quality 3/4" plywood tops. Tops are insulated from frames to reduce noise and vibration. Deck will accept 6 legs of 1 1/2" Schedule 40 steel pipe. Legs are held in place by a hand knob. Decks are connected to each other by bolting through pre-drilled holes along straight edges. Four left hand and four right hand decks around eight 4' x 8' decks make a 24' diameter circle. Can be used to round off stage corners.



Report OE-08-05-301

Rev. F
Section 6.0

6.0 Appendix: dwg HEAMS106103 Rev. 0, dated 4/17/07



Report OE-08-05-301

Rev. F
Section 6.0

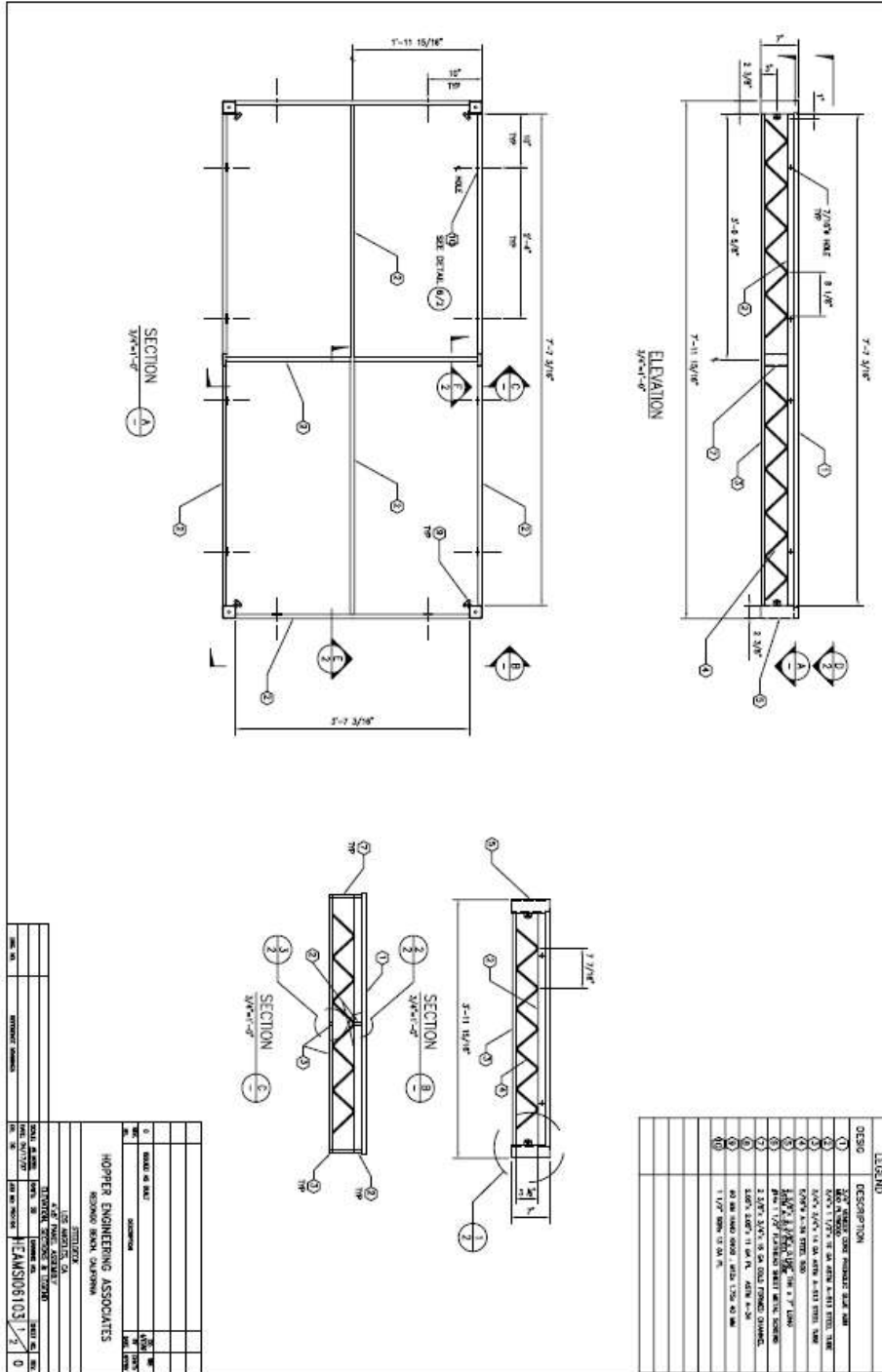

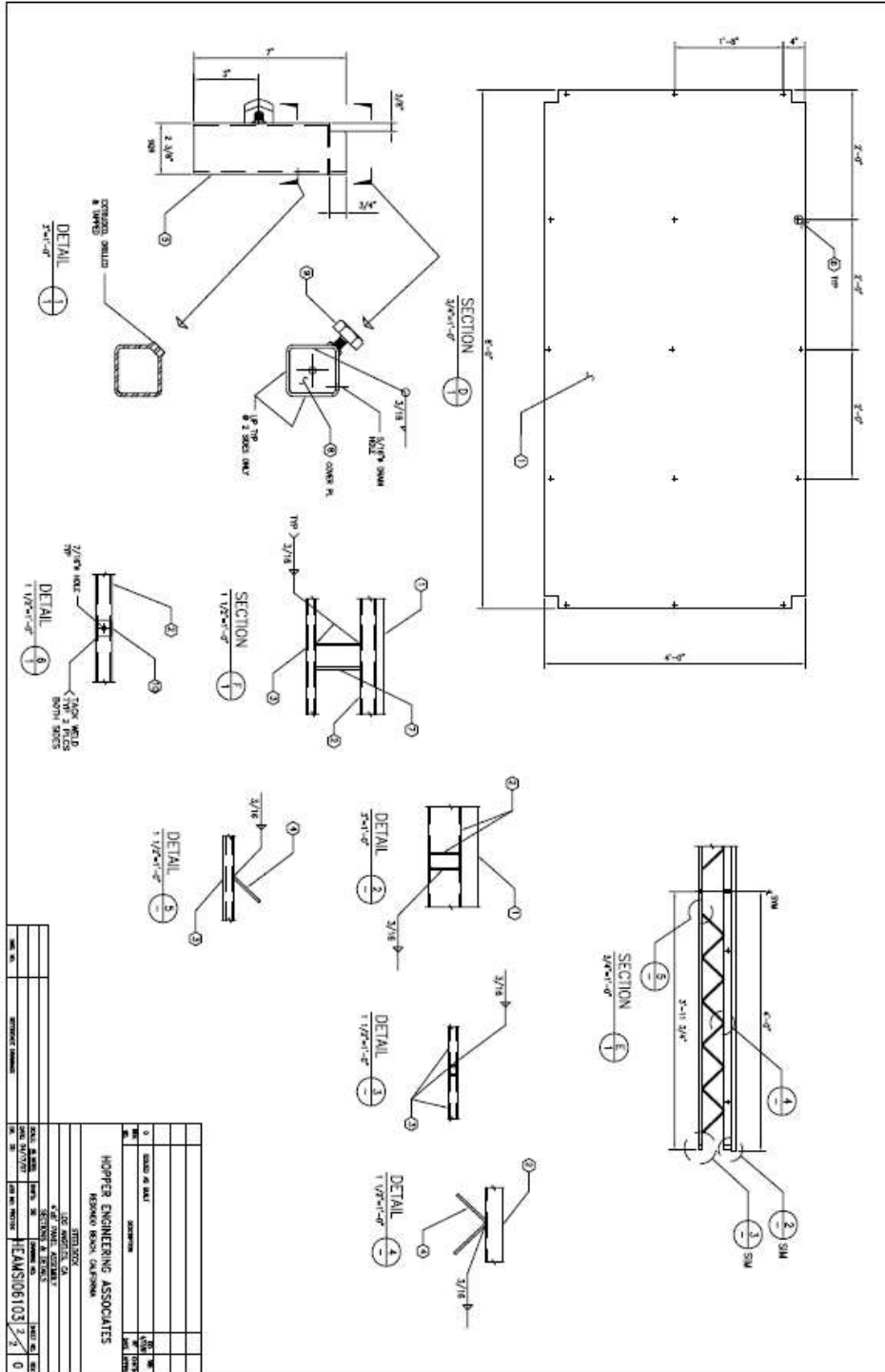

DATE	BY	CHKD BY	APP'D BY
08/05/03	HEAMS	HEAMS	HEAMS
HOPPER ENGINEERING ASSOCIATES HESPERO BRANCH, CALIFORNIA 2000 W. 10TH ST. HESPERO, CA 92541 (760) 937-1111 FAX (760) 937-1112 WWW.HOPPERENGINEERING.COM			
PROJECT NO.	08-05-301	DATE	08/05/03
REV.	0	DATE	08/05/03