



29979 Harvester Rd, Malibu, CA. 90265
Telephone: (818) 371-7128, e-mail: kodian@verizon.net

DOCUMENT NO. OE-08-05-303

**TEST REPORT:
FOUR FOOT HIGH
STEELDECK PLATFORM SYSTEMS
STRUCTURAL CAPACITY**

Revision D Dated March 8, 2026



Prepared for:

**Steeldeck, Inc.
13147 S Western Avenue
Gardena, CA 90249-1921**

Approved By:

Name (print):
Title:

Kirk Odian
President, M.S., P.E.

PROPRIETARY DOCUMENT

The Information herein is privileged and confidential and shall not be disseminated, duplicated, reused or disclosed in any way without the prior written permission of STEELDECK, Inc. or Odian Engineering, Inc.



Log of Revisions

Revision Letter	Page Number	Section	Description of Change
IR	all	all	Initial release
A	i, v, 1, 5 & 26	Ref., 1.0, 1.2 & 5.0	Included current CBC 2016 Compliance
B	Cover		Updated for new Steeldeck address.
C	Cover page, i-v, 1, 2, 5 & 26	1.0, 1.1, 1.2 & 5.0	Updated to cite compliance with latest CBC 2022 revision. Added Ref. 12. All headers updated to show "Rev. C". Updated pagination in ToC, LoF & LoT.
D	Cover page, i-v, 1, 5 & 26. 6.	1.0, 1.2 & 5.0. 1.3	Updated to cite compliance with latest CBC 2025 revision. Added Ref. 13. All headers updated to show "Rev. D". Grammatical correction.



Table of Contents

Log of Revisions	i
List of Figures	iii
List of Tables	iv
References	v
1.0 INTRODUCTION	1
1.1 Background.....	2
1.2 Test Objective.....	5
1.3 Previous Work	6
1.4 Limitations.....	8
2.0 EQUIPMENT, PROCEDURES AND TEST PARAMETERS	9
3.0 PLATFORM TEST	18
4.0 TEST RESULTS	25
5.0 SUMMARY OF FINDINGS	26
5.1 Other Steeldeck Offered Shape and Sized Decks Bounded by these Test Results	27
6.0 Appendix: dwg HEAMS106103 Rev. 0, dated 4/17/07	32



List of Figures

Figure 1-1	Standard STEELDECK® Rectangular Platforms.....	1
Figure 1-2	Typical STEELDECK® Common Leg Joint.....	3
Figure 1-3	Typical STEELDECK® Deck-to-deck Connecting Bolt Joint.....	4
Figure 1-4	Tributary Loading of Test Configuration Critical Central Leg.....	5
Figure 1-5	Manufacturer’s “Company Test”.....	6
Figure 2-1	Test Platform, 4 ft high.....	9
Figure 2-2	Test Platform, 4 ft high measured.....	10
Figure 2-3	Test Platform, 4 ft high, Long View from below	10
Figure 2-4	Square Steel Tube Stock Bundles, 19 ft 9 ½ in long, minimum	12
Figure 2-5	Zeroed out load cell with empty bucket.....	13
Figure 2-6	Weight of three feet of unit tube stock, 13.3 lbs → 4.433 lbs/ft.....	14
Figure 3-1	Load Step 2, Platform loaded to 102.9 lbs/ft ²	18
Figure 3-2	Load Step 3, S/N 22065 Deck max deflection, typical all decks @ 102.9 lbs/ft ²	19
Figure 3-3	Load Step 4, Platform loaded to 202.76 lbs/ft ²	20
Figure 3-4	Load Step 4, Platform loaded to 202.76 lbs/ft ² , Sag of long side beams	21
Figure 3-5	Load Step 4, Platform loaded to 202.76 lbs/ft ²	21
Figure 3-6	Load Step 4, Platform loaded to 202.76 lbs/ft ²	22
Figure 3-7	Platform Deck S/Ns and Test Deflection Measurements of Mid-point on Longest Spans	23
Figure 3-8	No distress of critical deck-to-deck bearing surfaces	24



Report OE-08-05-303

Rev. D

List of Tables

Table 2-1	Loading Sequence & Procedure.....	17
-----------	-----------------------------------	----



References

1. 2007 California Code of Regulations, Title 24, Part 2, *California Building Code*
2. 2001 California Code of Regulations, Title 24, Part 2, *California Building Code*
3. 1994 Uniform Building Code, Volume 2, Structural Engineering Design Provision.
4. Steeldeck, Set-up and Safety Manual, Rev. 5/2002.
5. Steeldeck, Platform Systems Catalog, May 2002.
6. British Standards Institution Specification BS 1139: Part 2: 1982, Metal Scaffolding.
7. British Standards Institution Specification BS EN 74-1:2005, Couplers, spigot pins and baseplates for use in falsework and scaffolds, Part 1: Couplers for tubes – Requirements and test procedures.
8. 4'x 8' Steeldeck® Platform Evaluation, Rev. 1 dated April 2007, Hopper Engineering Associates, PRO 196
9. 2013 California Code of Regulations, Title 24, Part 2, California Building Code
10. Odiان Engineering Test Rpt. No.: OE-08-05-301; Steeldeck Platform Systems Structural Capacity, Rev. C dated March 10, 2016, or later approved revision.
11. 2016 California Code of Regulations, Title 24, Part 2, California Building Code.
12. 2022 California Code of Regulations, Title 24, Part 2, California Building Code.
13. **2025 California Code of Regulations, Title 24, Part 2, California Building Code.**



1.0 INTRODUCTION

This test report presents independent testing and findings conducted by Oedian Engineering of the Steeldeck® 4 ft x 8 ft platform system on 4 ft legs. Prior testing of the platform system on 3 ft legs was carried out and reported in Reference 10. **Revision IR of this test report** on the 4 ft leg system **showed** continued compliance with the **then** current 2013 California Code of Regulations, Title 24, Part 2, Chapters 16 & 17, **including the full 24 hour dwell testing results per Section 1709A.3.2**. The subsequent Revision A of this test report showed continued compliance with the then current 2016 California Code of Regulations, Title 24, Part 2, Chapters 16 & 17. **This subsequent Revision C of this test report shows continued compliance with the current 2025 California Code of Regulations, Title 24, Part 2, Chapters 16 & 17.** A system of five (5) 4 ft x 8 ft decks, assembled in accordance with the manufacturer's Set-up and Safety Manual (Ref. 4) was tested. This configuration was chosen as it contains the largest free span of the typical deck components offered, and it subjects the deck and leg support joints with the most critical loading. As such, these test results bound a number of smaller, less critical deck components offered as will be discussed in the Summary.

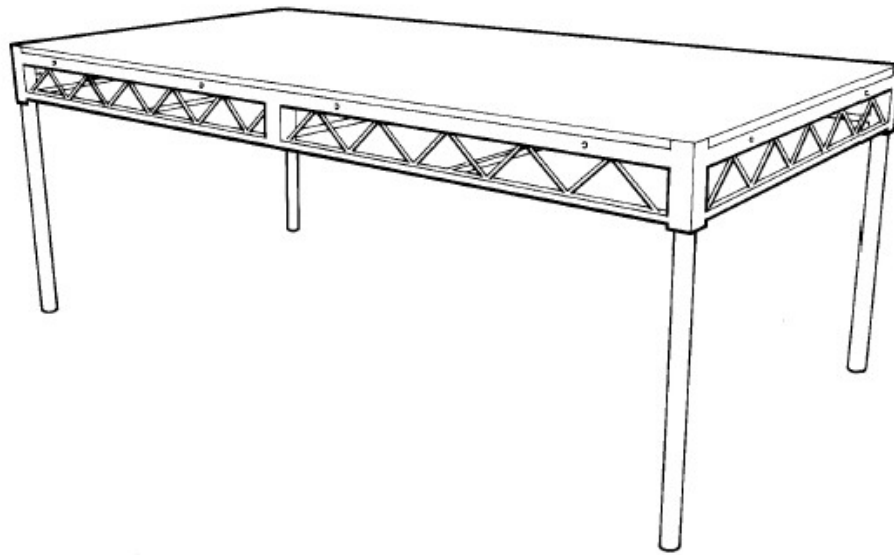

Figure 1-1 Standard STEELDECK® Rectangular Platforms



1.1 Background

Steeldeck manufactures platform systems for sale and rent. These systems are typically employed as assembled platforms in various private and sometimes public venues. Often, the platforms are assembled as a connected system to erect a large platform of variable shape. This is accomplished by virtue of the modular design and the ability to connect the individual platforms of different sizes and shapes together.

As previously stated, a system of five (5) 4 ft x 8 ft decks assembled together as an 8 ft x 20 ft rectangular platform 4 ft high was selected as the test configuration. This configuration was selected since it represents the critical spans, maximum joint loading and a typical platform height. Additionally, this assembled platform overall dimension was sized to accommodate the approximately 20 ft long steel bundles of tare weight employed for the test load.

When erecting an assembled platform, the first deck is set on four (up to six for some shapes) corner legs which are captured in the corner sockets. On legs which will be common to the adjoining decks, couplers are provided as an assembly aid. The couplers provide a temporary support for the neighboring platforms to be placed on (see Reference 5, Steeldeck catalog, and Figure 1-2 herein). Note, newer design couplers are now welded integrally to the legs for a reduction of piece parts, and to provide a redundant load path to the supporting leg when multiple decks interface and are supported by a common leg. The neighboring decks receive legs in their outboard corner sockets which do not rest on the first deck's couplers. At the common edges of all decks, frame connecting bolts are installed which secure the two decks together. Thus, the central leg common to the first deck in the selected test platform configuration will bear $\frac{1}{4}$ of the live load from the four assembled decks. The following Figures show the typical platform erection process, erection aid couplers, fixed deck-to-deck connection bolts and the critical test assembly and load sharing.

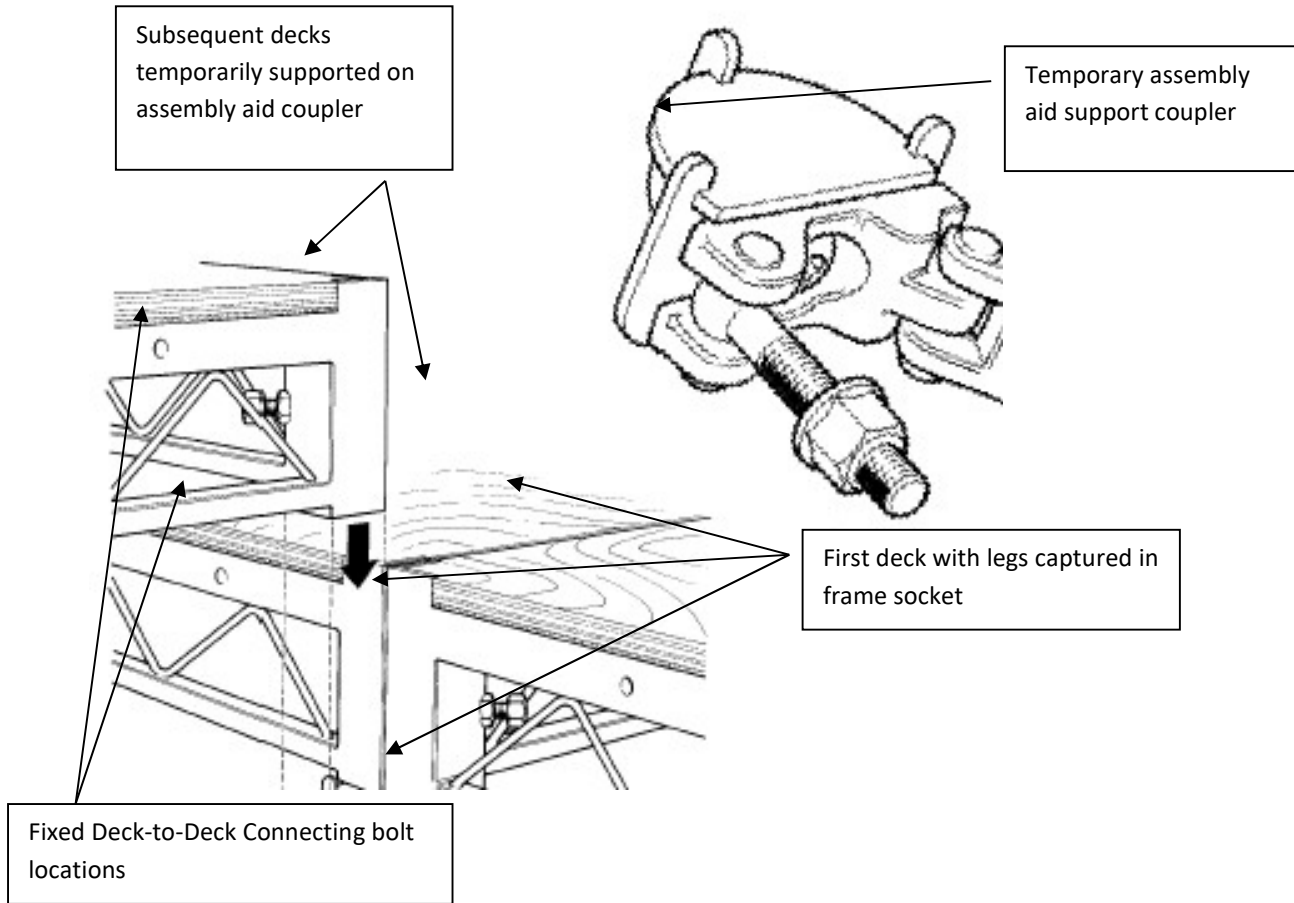

Figure 1-2 Typical STEELDECK® Common Leg Joint



Figure 1-3 Typical STEELDECK® Deck-to-deck Connecting Bolt Joint

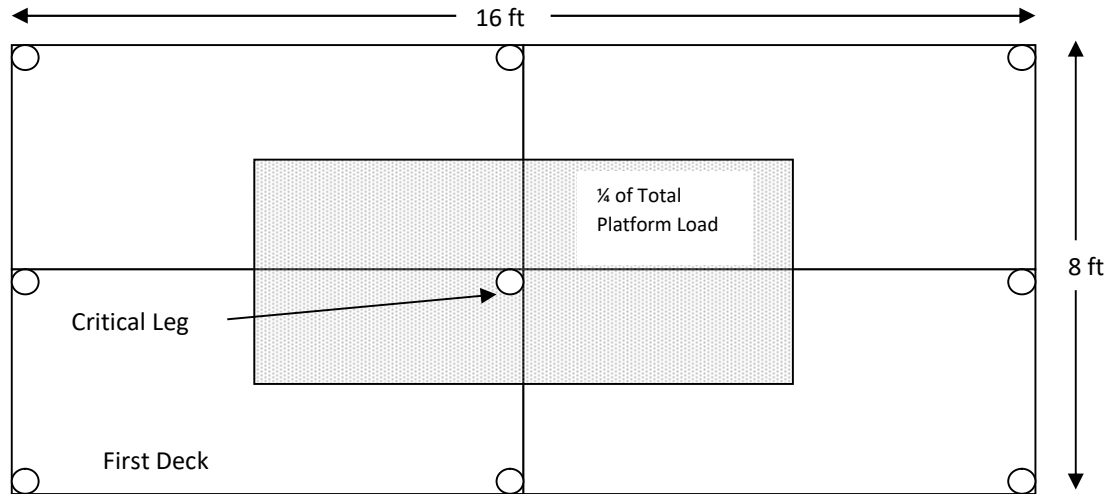

Figure 1-4 Tributary Loading of Test Configuration Critical Central Leg

1.2 Test Objective

The **2025** California Code of Regulations, Title 24, Part 2, Chapters 16, Table 1607.1, Minimum Uniformly Distributed Live Loads and Minimum Concentrated Live Loads, establishes the required loading for platforms (assembly) as 100 lbs/ft². Section 1709 of the same code sets forth In-Situ Load Test methodology. Consistent with the intent of Section 1709, the objective of this testing was to subject the platform assembly to two times the unfactored Design Load ($2 \times 100 = 200$ lbs/ft²) for a 24 hour dwell period. The test procedure employed has been developed by this author, a registered Professional Engineer in the State of California. The test procedure simulates loads and conditions of application that the completed structure or portion thereof will be subjected to in normal use. **Due to temporary erection, negligible lateral section area, and primarily indoor or covered or protected applications, the testing ignored any wind loading effects.** The structure shall be considered to have successfully met the test requirements where the following criteria are satisfied:

1. Under the Design Load, the deflection shall not exceed the limitations specified in California Code of Regulations, Title 24, Part 2, Section 1604.3 (longest span/360 inches).
2. Within 24 hours after removal of the test load, the structure shall have recovered not less than 75 percent of the maximum deflection.
3. During and immediately after the test, the structure shall not show evidence of failure.

1.3 Previous Work

Reference 8 contains an analytical structural substantiation of the same 4 ft x 8 ft Standard deck. That analysis was performed by Hopper Engineering under the supervision and approval of a Registered Professional Engineer. The analysis contained both classical closed form hand calculations as well as a detailed Finite Element Analysis of the deck. A Design Load of 125 lbs/ft² was substantiated in that report.

The subject platform systems, as designed, have been in use for over 20 years primarily in the entertainment industry. They have been subjected to on the job in-situ loading of similar magnitude reportedly without any catastrophic incident. Typically, the on the job loading demands placed on the platforms are far less than the aforementioned design requirements.

The manufacturer conducted a similar test as that proposed herein; “Company Test”. He erected a 2 ft high, four 4 ft x 8 ft deck platform and loaded one deck quadrant with 12,700 lbs of tare weight in racks. This represented nearly 400 lbs/ft², but the load was not necessarily uniformly loaded, and only one deck quadrant was loaded.



Figure 1-5 Manufacturer’s “Company Test”

Reference 10 presents prior testing accomplished by this author on a three foot tall system. 8 ft x 16 ft rectangular platforms were erected on a flat concrete floor inside a warehouse. The platforms consisted of four Standard 4 ft x 8 ft decks, conforming to dwg HEAMS106103 Rev. 0, which were set on 3 ft legs (1-1/2 Schedule 40 steel pipe) and adjoined together as per the standard procedures outlined in the preceding and in Reference 4. The platforms were then sequentially loaded with bags of cement tare in order to achieve conservative total loading in excess of the requirements. Below is a photo from that testing at 271 lbs/ft² area loading.



Figure 1-6 3 Ft High Platform loaded to 271.0 lbs/ft²



1.4 Limitations

The results of the testing proposed herein is limited to the following:

1. Deck modules made of the same grade and truss beam configuration as that which was tested (per dwg HEAMS106103 Rev. 0, dated 4/17/07).
2. Deck modules which are smaller or configured with denser support structure resulting in overall lower loading per maximum span, and lower loading per critical leg joint and deck-to-deck connecting bolted joints.
3. Platforms erected to a maximum height of 4 feet.
4. Vertical Live Load conditions.

2.0 EQUIPMENT, PROCEDURES AND TEST PARAMETERS

An 8 ft x 20 ft rectangular platform was erected on a flat concrete floor inside the Steedeck warehouse. The platform consisted of five Standard 4 ft x 8 ft decks, conforming to dwg HEAMS106103 Rev. 0, which were set on 4 ft legs (1-1/2 Schedule 40 steel pipe) and adjoined together as per the standard procedures outlined in the preceding and in Reference 4. All equipment and hardware were randomly selected from rental stock to ensure a typical “as used” condition. The platform size erected was chosen to match that of approximately 20 ft long steel tube stock to be used as tare weight.



Figure 2-1 Test Platform, 4 ft high



Figure 2-2 Test Platform, 4 ft high measured



Figure 2-3 Test Platform, 4 ft high, Long View from below



Live load consisted of bundles of 19' 9 1/2" long (= 19.8 ft), structural tube steel stock used to fabricate the platform framing. There are 25 tubes in each bundle. The running weight of the tube stock was derived by measuring three one foot segments of the tube stock selected at random. The three one foot segments weighed 13.3 lbs collectively giving a unit running weight of 4.433 lbs/ft for the tube stock. The bundles of tube stock were placed by fork lifts onto five robust wooden pallets which served to overlap the platform deck joints and help distribute the load uniformly. Each wooden pallet weighed equal to or in excess of 221 lbs. Therefore, when loading one layer of 7 bundles onto the 5 wooden pallets, we achieve a total areal tare weight of $(4.433\text{lb/ft} * 19.8\text{ ft} * 25\text{ tubes/bundle} * 7\text{ bundles} + 5\text{ pallets} * 221\text{ lbs/pallet}) / (5 * 4\text{ ft} * 8\text{ ft}) = 102.9\text{ lbs/ft}^2$.

To achieve the 2xDesign Load of 200 lbs/ft², a second level of 7 more bundles were added, along with one single tube on top of each bundle stack (seven total single tubes). This generated a total areal tare weight of $(4.433\text{lb/ft} * 19.8\text{ ft} * 25\text{ tubes/bundle} * 7\text{ bundles} * 2\text{ layers} + 4.433\text{lb/ft} * 19.8\text{ ft} * 7\text{ single tubes} + 5\text{ pallets} * 221\text{ lbs/pallet}) / (5 * 4\text{ ft} * 8\text{ ft}) = 202.76\text{ lbs/ft}^2$.



Figure 2-4 Square Steel Tube Stock Bundles, 19 ft 9 ½ in long, minimum



Figure 2-5 Zeroed out load cell with empty bucket



Figure 2-6 Weight of three feet of unit tube stock, 13.3 lbs → 4.433 lbs/ft



Figure 2-7 Single Wooden Pallet



Figure 2-8 4 ft. tall 8x20 ft. Platform with wooden pallets in place, overlapping deck seams



Figure 2-9 4 ft. tall 8x20 ft. Platform with ≥ 221 lb wooden pallets in place, overlapping deck seams



The platform was tested in seven steps total. The first step measured the max span mid-point heights of each deck in the assembled platform for initial unloaded conditions. The second step applied the Design Load of 100 lbs/ ft² (actual 102.9 lbs/ft²). The third step measured the maximum deflections of each deck. The fourth step applied 2*Design Load of 200 lbs/ ft² (actual 202.76 lbs/ft²) for a 24 hour dwell. The fifth step measured the maximum deflections of each deck post 24 hour dwell. The sixth step unloaded the platform post dwell period. The seventh step measured for deflection recovery. The following table summarizes the load steps and applied distributed loading.

Table 2-1 Loading Sequence & Procedure

Load Step	Distributed Load (lbs/ft²)	Dwell Time (hrs:min:sec)
1	Measure max span midpoint heights of each deck	
2	102.9	Aprpx 15:00
3	Measure max spans vertical deflections at midpoint, check any signs of distress.	
4	202.76	24:37:00
5	Measure max spans vertical deflections at midpoint, check any signs of distress.	
6	Unload the entire platform after 24 hr dwell and check for and document any signs of distress.	
7	Measure max spans mid-point heights and verify deflection recovery.	

3.0 PLATFORM TEST

On December 2, 2015, this author conducted the platform tests as described in the preceding chapter and as shown in the following photographs. All phases of the platform erection, loading and unloading were witnessed by this author. Intermediate inspections and teardown inspections of the test articles were carried out by this author.



Figure 3-1 Load Step 2, Platform loaded to 102.9 lbs/ft²



Figure 3-2 Load Step 3, S/N 22065 Deck max deflection, typical all decks @ 102.9 lbs/ft²



Figure 3-3 Load Step 4, Platform loaded to 202.76 lbs/ft²



Figure 3-4 Load Step 4, Platform loaded to 202.76 lbs/ft², Sag of long side beams



Figure 3-5 Load Step 4, Platform loaded to 202.76 lbs/ft²



Figure 3-6 Load Step 4, Platform loaded to 202.76 lbs/ft²

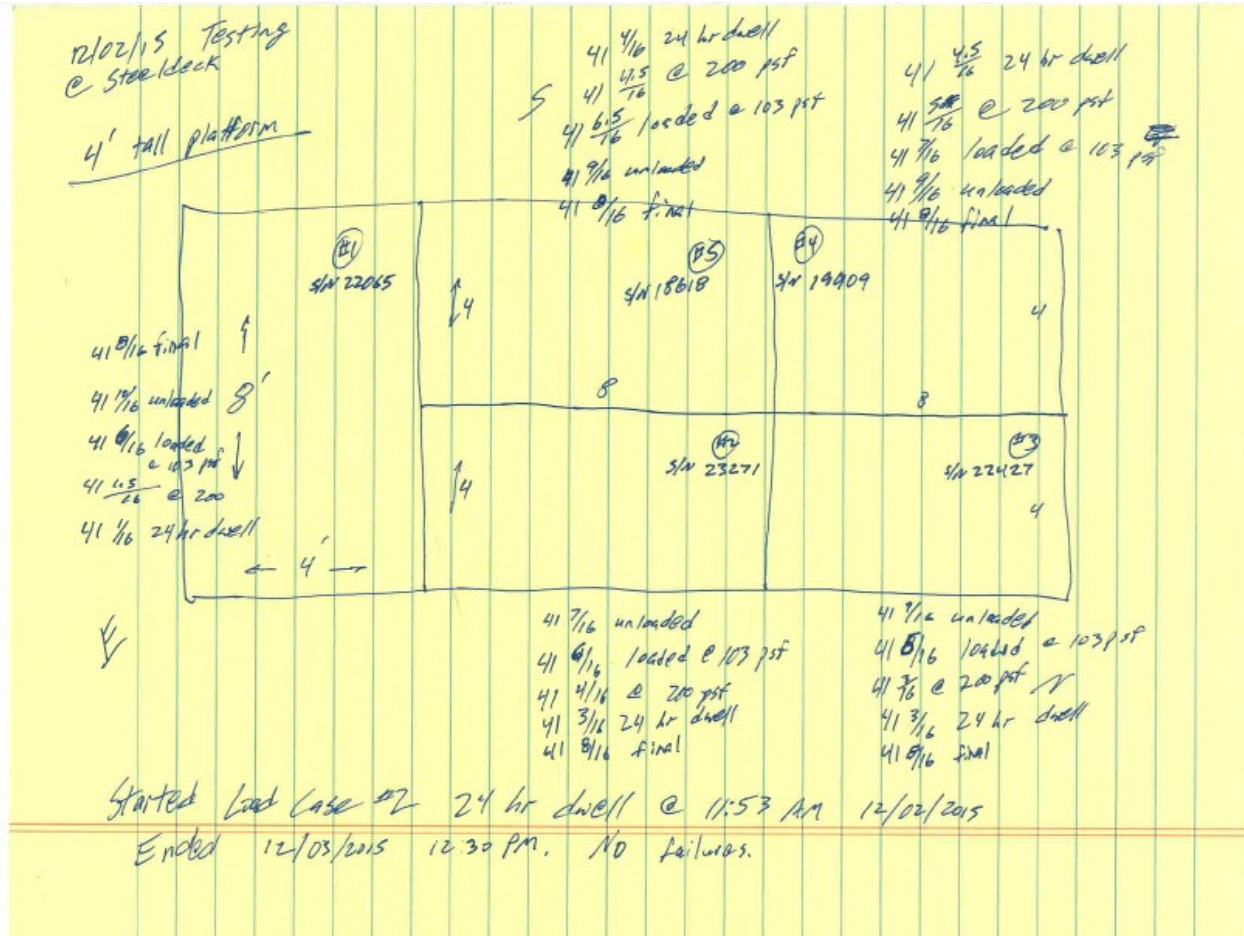

Figure 3-7 Platform Deck S/Ns and Test Deflection Measurements of Mid-point on Longest Spans

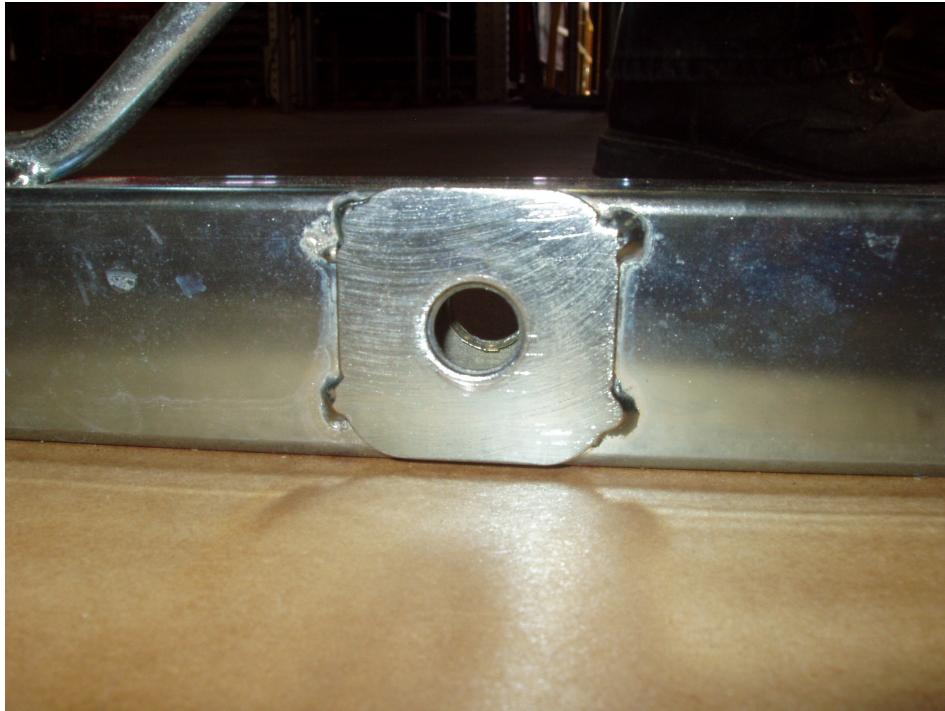

Figure 3-8 No distress of critical deck-to-deck bearing surfaces



4.0 TEST RESULTS

The structure successfully met the test requirements as follows:

1. Under the conservative Design Load (100 lbs/ft²), the deflection shall not exceed the limitations specified in California Code of Regulations, Title 24, Part 2, Section 1604.3 (longest span/360 inches).

Result: Range of 0.125 to 0.250 inches of maximum Sag deflection measured at mid span of the long 8 ft beams under a conservative 102.9 lbs/ft² Design Load. 0.250" < (8ft*12in/ft)/360 = 0.2667 inches allowed.

2. Within 24 hours after removal of the test load, the structure shall have recovered not less than 75 percent of the maximum deflection.

Result: All decks recovered \geq 75% of their maximum deflection upon unloading the maximum 202.76 lbs/ft² loading (= 203% Design Load). (Actuals by Deck #: #1 77%, #2 100%, #3 83%, #4 75.0%, #5 78%)

3. During and immediately after the test, the structure shall not show evidence of failure.

Result: At no time during the test or upon teardown inspection were any failures evident.



5.0 SUMMARY OF FINDINGS

The subject Steeldeck® Standard platforms fabricated in accordance with dwg HEAMS106103 Rev. 0, dated 4/17/07 and erected on four foot tall Steeldeck® legs were found to meet and exceed the minimum performance standards of applicable **2025** California Code of Regulations, Title 24, Part 2.

When comparing the design of the critical 4'x 8' Standard deck, to that of the design and configuration of a number of other Steeldeck® offered shapes and sizes fabricated with the same grade and construction as per dwg HEAMS106103 Rev. 0, dated 4/17/07, and also erected on four foot tall Steeldeck® legs (or shorter), it is found by inspection that these test results are bounding. This is due to the fact that the other offered shapes and sizes have smaller unsupported spans and greater numbers of legs and deck-to-deck fixed connections per tributary load than the critical 4'x 8' Standard platform on four legs. Thus, these other shapes and sizes are less critically loaded while maintaining equal or superior capacity. The list of these other Steeldeck® offered shapes and sizes which are considered bounded by this testing is provided in the following Section 5.1

A Design Load rating of 100 lbs/ft² is acceptable for all the Steeldeck® platform products listed herein.

5.1 Other Steeldeck Offered Shape and Sized Decks Bounded by these Test Results

The following lists the other Steeldeck[®] offered shapes and sizes, which when fabricated with the same grade and construction as per dwg HEAMS106103 Rev. 0, dated 4/17/07, are found to be bounded by the tests herein.

Rectangular

4' x 8'

3' x 8'

2' x 8'

4' x 6'

3' x 6'

2' x 6'

4' x 4' (square)

3' x 4'

2' x 4'

3' x 3'

2' x 3'

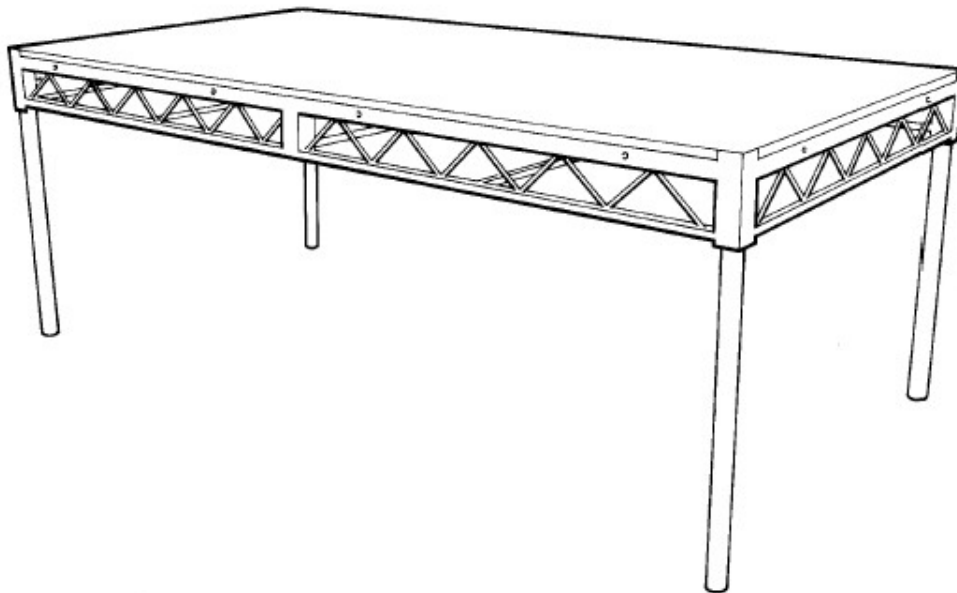



Report OE-08-05-303

Rev. D
Section 5.0

Triangles

4' x 4'

3' x 3'

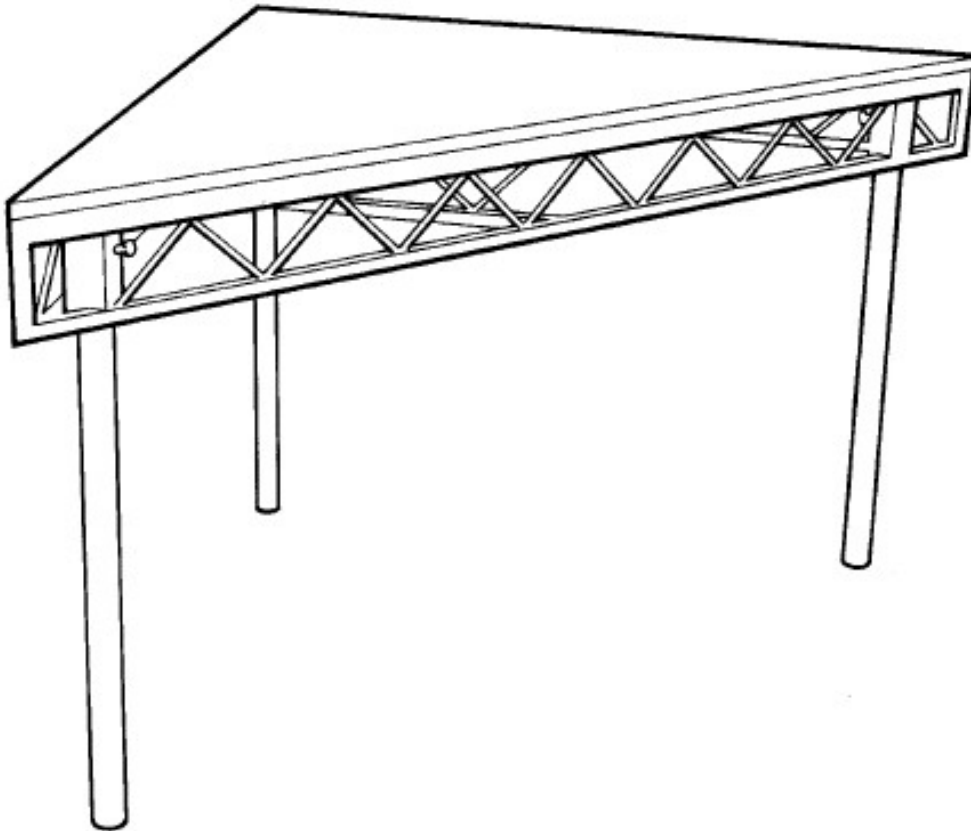

Circles

4' diameter (whole circle)



3' Quadrant Deck

6' diameter (3' x 3' quadrants)

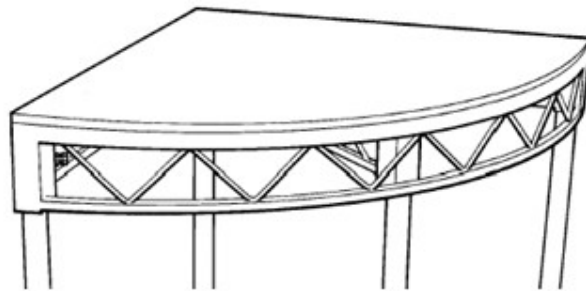

8' diameter (4' x 4' quadrants)

4' Quadrant Deck

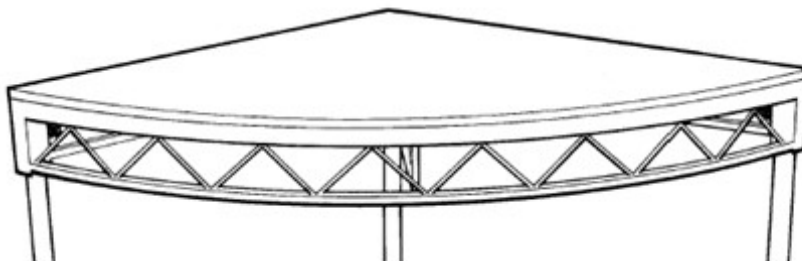

10' diameter (5' x 5' quadrants)

I 5' Quadrant Deck

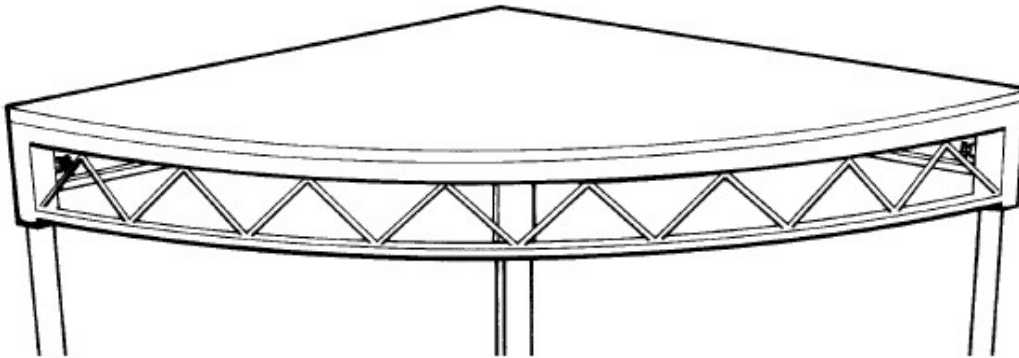

12' diameter (6' x 6' quadrants)

6' Quadrant Deck

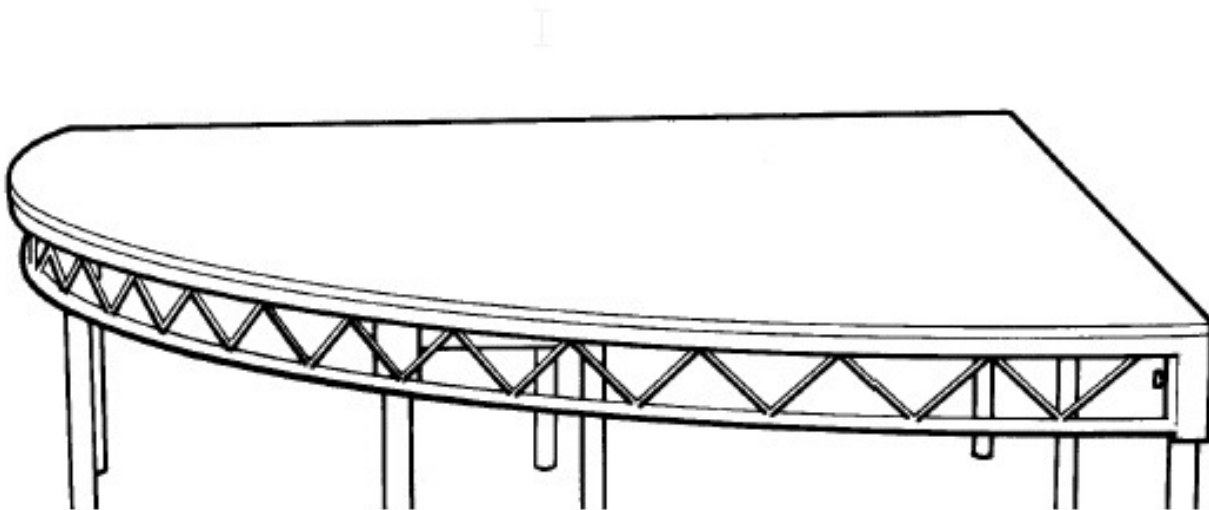

16' diameter (4' x 4' x 5.5' shapes, Left and Right) shown below, top left,
20' diameter (4' x 6' x 7' shapes, Left and Right) shown below top right,
24' diameter (4' x 8' x 8.5' shapes, Left and Right) shown below bottom.

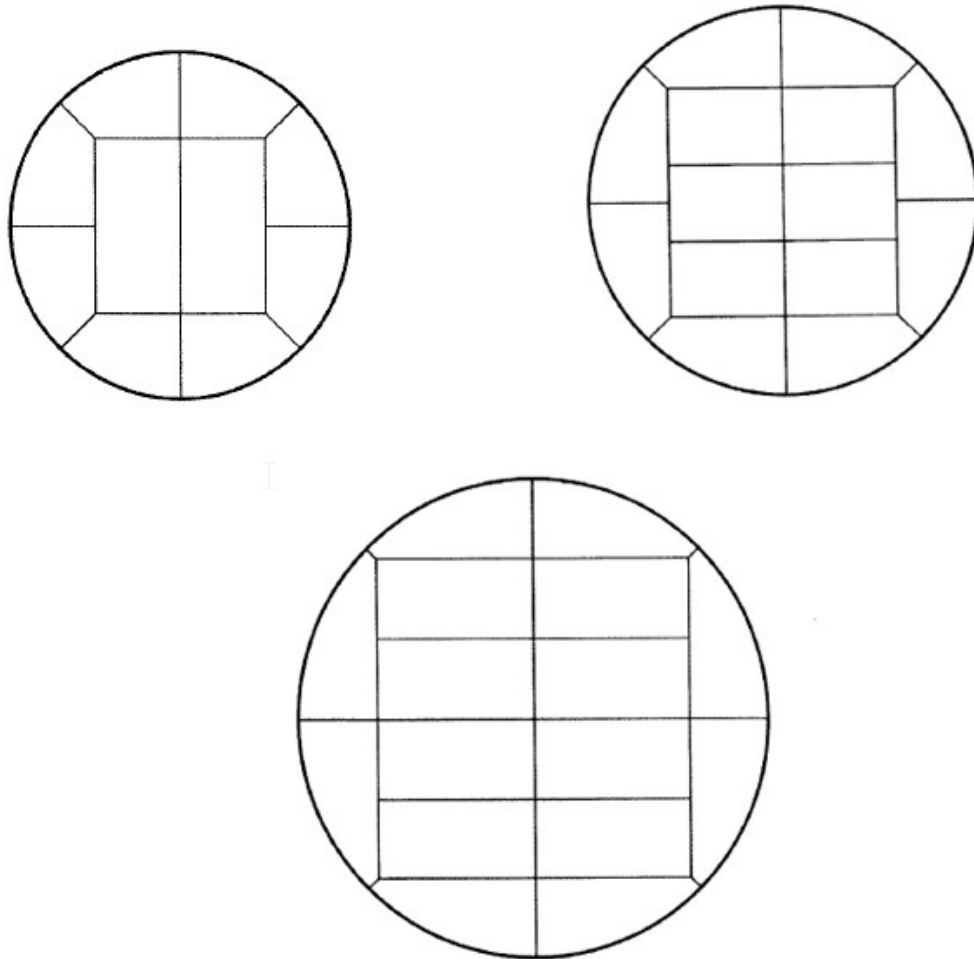

DESCRIPTION:

24' Diameter Deck. Same construction as standard Steeldeck® platform using steel truss frame with high quality 3/4" plywood tops. Tops are insulated from frames to reduce noise and vibration. Deck will accept 6 legs of 1 1/2" Schedule 40 steel pipe. Legs are held in place by a hand knob. Decks are connected to each other by bolting through pre-drilled holes along straight edges. Four left hand and four right hand decks around eight 4' x 8' decks make a 24' diameter circle. Can be used to round off stage corners.

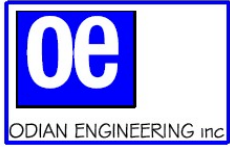

Report OE-08-05-303

Rev. D
Section 6.0

6.0 Appendix: dwg HEAMS106103 Rev. 0, dated 4/17/07

